

»filter plug« type

For mounting on pneumatic tools and protecting them against impurities, especially in dirty or dusty working environments.

Inline filters

- Extend the service life of the tool
- Do not impair the flow
- Assure the oil mist supply to the tool

Designed for use with standard DN 7.2 couplings

Housing:	Hardened, nickel-plated steel
Thread:	Nickel-plated brass
Filter element:	Sintered bronze
Working pressure:	Max. 10 bar
Temperature range:	0 °C bis +90 °C
Weight:	50 g
Hexagon:	3/4 "



650.91

inline-filters		
Art. No.	Type No.	Thread
101524	650.91	R 1/4
101525	650.92	R 3/8

Filter element		
Art. No.	Type No.	Suitably to
101526	650.95	650.91 and 650.92

Dimensions:

Art. No. 101524 - Type No. 650.91

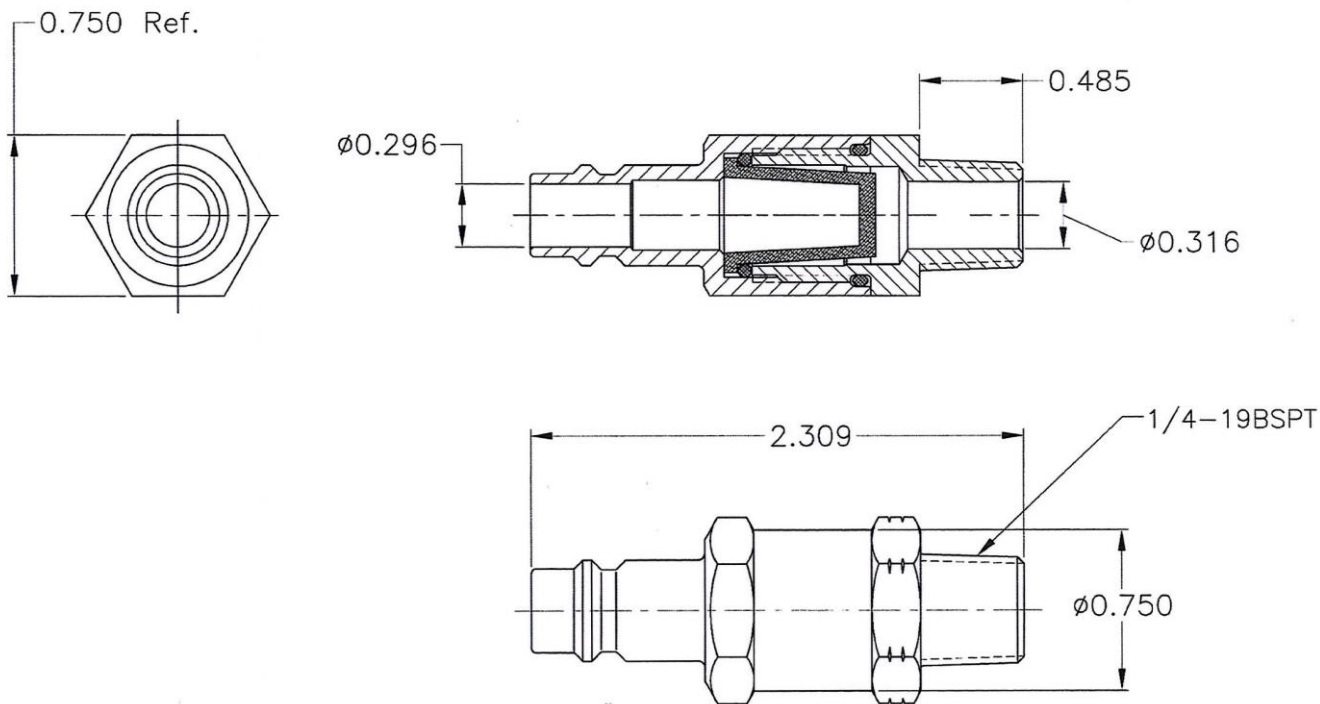

Art. No. 101525 - Type No. 650.92

